

COMPOSITE TANK

TOP STACK DIFFUSER SYSTEM  
WITH 16" MANWAY  
30" THRU 63" DIA. TANK

STRUCTURAL

NORTH AMERICA

10877

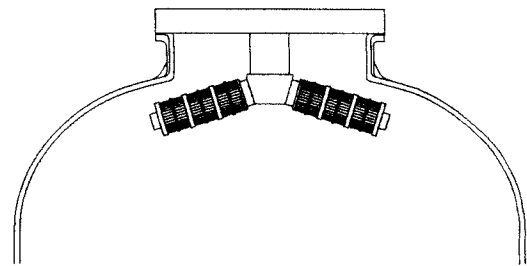
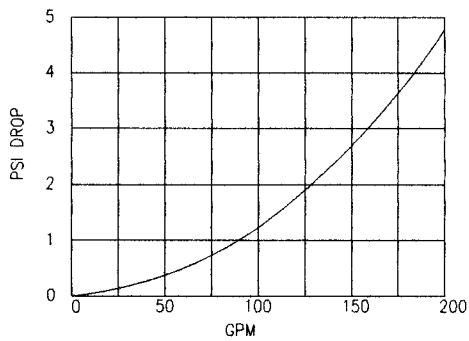
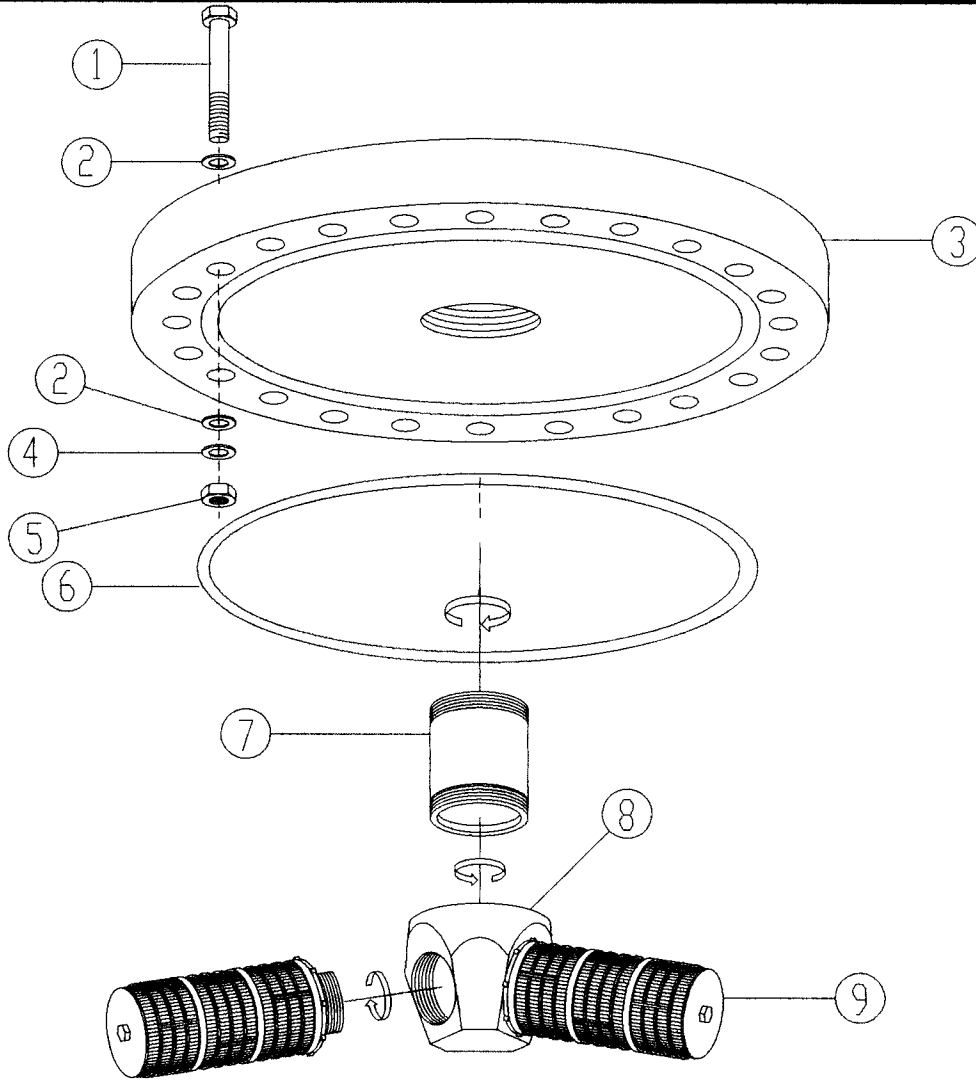

ITEM	DESCRIPTION	DIMENSION	QUANTITY	ITEM NUMBER
1	BOLT	1/2" X 4-1/2" STAINLESS STEEL	24	10107-1
2	WASHER	1/2" FLAT - STAINLESS STEEL	48	5262-4
3	ADAPTER	16" FLANGE ADAPTER TO 3" NPT (TAPPED FROM BOTH SIDES)	1	10478-7
4	WASHER	1/2" LOCK - STAINLESS STEEL	24	5262-3
5	NUT	1/2"-13 STAINLESS STEEL	24	5262-2
6	O-RING	18-1/2" I.D. (MATERIAL IS EPDM)	1	2694-131
7	PIPE	3" NPT THREAD TO 3" BSP THREAD	1	5063
8	HUB	5" DIA., 3" BSP THRD X 2 1/2"-8 NPSM THREAD	1	10313
9	DIFFUSER	7" X .008" SLOT (180mm x 0.2mm)	3	5721